

PERFORMANCE  
MADE  
SMARTER

# Product manual **5337**

## **2-wire transmitter with HART protocol**



TEMPERATURE | I.S. INTERFACES | COMMUNICATION INTERFACES | MULTIFUNCTIONAL | ISOLATION | DISPLAY

No. 5337V105-UK  
Serial no.: 180971088-210947732

**PR**  
electronics

# 6 Product Pillars

## *to meet your every need*

### Individually outstanding, unrivalled in combination

With our innovative, patented technologies, we make signal conditioning smarter and simpler. Our portfolio is composed of six product areas, where we offer a wide range of analog and digital devices covering over a thousand applications in industrial and factory automation. All our products comply with or surpass the highest industry standards, ensuring reliability in even the harshest of environments and have a 5-year warranty for greater peace of mind.

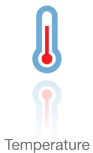

Our range of temperature transmitters and sensors provides the highest level of signal integrity from the measurement point to your control system. You can convert industrial process temperature signals to analog, bus or digital communications using a highly reliable point-to-point solution with a fast response time, automatic self-calibration, sensor error detection, low drift, and top EMC performance in any environment.



We deliver the safest signals by validating our products against the toughest safety standards. Through our commitment to innovation, we have made pioneering achievements in developing I.S. interfaces with SIL 2 Full Assessment that are both efficient and cost-effective. Our comprehensive range of analog and digital intrinsically safe isolation barriers offers multifunctional inputs and outputs, making PR an easy-to-implement site standard. Our backplanes further simplify large installations and provide seamless integration to standard DCS systems.



We provide inexpensive, easy-to-use, future-ready communication interfaces that can access your PR installed base of products. All the interfaces are detachable, have a built-in display for readout of process values and diagnostics, and can be configured via push-buttons. Product specific functionality includes communication via Modbus and Bluetooth and remote access using our PR Process Supervisor (PPS) application, available for iOS and Android.



Our unique range of single devices covering multiple applications is easily deployable as your site standard. Having one variant that applies to a broad range of applications can reduce your installation time and training, and greatly simplify spare parts management at your facilities. Our devices are designed for long-term signal accuracy, low power consumption, immunity to electrical noise and simple programming.



Our compact, fast, high-quality 6 mm isolators are based on microprocessor technology to provide exceptional performance and EMC-immunity for dedicated applications at a very low total cost of ownership. They can be stacked both vertically and horizontally with no air gap separation between units required.



Our display range is characterized by its flexibility and stability. The devices meet nearly every demand for display readout of process signals, and have universal input and power supply capabilities. They provide a real-time measurement of your process value no matter the industry, and are engineered to provide a user-friendly and reliable relay of information, even in demanding environments.

# 2-wire transmitter with HART protocol 5337

## Table of contents

Technical characteristics .....	4
Mounting / installation / programming .....	4
Applications .....	4
Order .....	5
Electrical specifications .....	5
Accessories .....	5
Changing the HART protocol version .....	8
Changing the HART protocol version using the PReset software and 5909 Loop Link or HART communication interface .....	8
Connections .....	11
Block diagram .....	12
Programming .....	12
Connection of transmitters in multidrop mode .....	14
Mechanical specifications .....	14
Mounting of sensor wires .....	14
ATEX Installation Drawing - 5337A .....	15
ATEX Installation Drawing - 5337D .....	17
IECEX Installation Drawing - 5337A .....	19
IECEX Installation Drawing - 5337D .....	20
CSA Installation Drawing - 5337A .....	22
CSA Installation Drawing - 5337D .....	23
FM Installation Drawing - 5337D .....	24
INMETRO Installation Drawing - 5337D .....	26
Document history .....	29

# 2-wire transmitter with HART protocol 5337

- RTD, TC, Ohm, or mV input
- 2 analog inputs and 5 device variables with status available
- HART protocol revision selectable from HART 5 or HART 7
- Hardware assessed for use in SIL applications
- Mounting on a DIN rail in safe area or hazardous gas and dust area

## Application

- Linearised temperature measurement with TC and RTD sensors e.g. Pt100 and Ni100.
- HART communication and 4...20 mA analogue PV output for individual, difference or average temperature measurement of up to two RTD or TC input sensors.
- Conversion of linear resistance to a standard analogue current signal, e.g from valves or Ohmic level sensors.
- Amplification of bipolar mV signals to standard 4...20 mA current signals.
- Up to 63 transmitters (HART 7) can be connected in a multidrop communication setup.

## Technical characteristics

- HART protocol revision can be changed by user configuration to either HART 5 or HART 7 protocol.
- The HART 7 protocol offers:
  - Long Tag numbers of up to 32 characters.
  - Enhanced Burst Mode and Event notification with time stamping.
  - Device variable and status mapping to any dynamic variable PV, SV, TV or QV.
  - Process signal trend measurement with logs and summary data.
  - Automatic event notification with time stamps.
  - Command aggregation for higher communication efficiency.
- 5337 is designed according to strict safety requirements and is therefore suitable for applications in SIL installations.
- Continuous check of vital stored data.
- Meeting the NAMUR NE 21 recommendations, the 5337 HART transmitter ensures top measurement performance in harsh EMC environments. Additionally, the 5337 meets NAMUR NE43 and NE89 recommendations.

## Mounting / installation / programming

- For DIN form B sensor head or DIN rail mounting via the PR fitting type 8421.
- Configuration via standard HART communication interfaces or by PR 5909 Loop Link.

## Applications

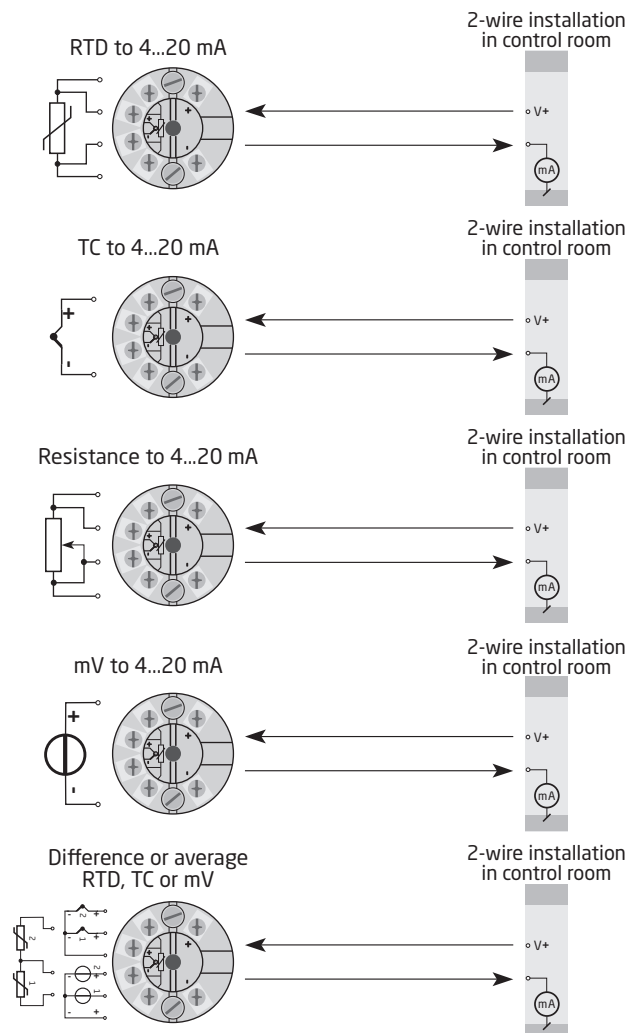

## Order

Type	Version
5337	Zone 2 / Div. 2 : A
	Zone 0, 1, 2, 20, 21, 22, M1 / DIV. 1, DIV. 2 : D

## Accessories

5909 = Loop Link USB interface and PReset Software  
8421 = DIN rail clip

## Electrical specifications

### Environmental conditions:

Specification range . . . . . -40°C to +85°C  
Calibration temperature. . . . . 20...28°  
Humidity. . . . . < 95% RH (non-cond.)  
Protection degree (encl./terminal) . . . . . IP68 / IP00

### Mechanical specifications:

Dimensions . . . . . Ø 44 x 20.2 mm  
Weight approx. . . . . 50 g  
Max. wire size. . . . . 1 x1.5 mm<sup>2</sup> stranded wire  
Screw terminal torque. . . . . 0.4 Nm  
Vibration. . . . . IEC 60068-2-6  
2...25 Hz. . . . . ±1.6 mm  
25...100 Hz . . . . . ±4 g

### Common specifications:

Supply voltage, DC  
5337A . . . . . 8.0...35 VDC  
5337D . . . . . 8.0...30 VDC  
Internal power dissipation  
5337A . . . . . 25 mW...0.8 W  
5337D . . . . . 25 mW...0.7 W  
Voltage drop . . . . . 8.0 VDC  
Isolation voltage, test / operation. . . . . 1.5 kVAC / 50 VAC  
Programming . . . . . Loop Link & HART  
Signal / noise ratio . . . . . > 60 dB  
Response time (programmable) . . . . . 1...60 s  
Signal dynamics, input . . . . . 22 bit  
Signal dynamics, output . . . . . 16 bit

Accuracy, the greater of general and basic values:

General values		
Input type	Absolute accuracy	Temperature coefficient
All	$\leq \pm 0.05\%$ of span	$\leq \pm 0.005\%$ of span / °C

Basic values		
Input type	Basic accuracy	Temperature coefficient
Pt50 - Pt1000	$\leq \pm 0.1^\circ\text{C}$	$\leq \pm 0.005^\circ\text{C}/^\circ\text{C}$
Ni50 - Ni1000	$\leq \pm 0.2^\circ\text{C}$	$\leq \pm 0.005^\circ\text{C}/^\circ\text{C}$
Lin. R	$\leq \pm 0.1 \Omega$	$\leq \pm 5 \text{ m}\Omega / ^\circ\text{C}$
Volt	$\leq \pm 10 \mu\text{V}$	$\leq \pm 0.5 \mu\text{V} / ^\circ\text{C}$
TC type: E, J, K, L, N, T, U	$\leq \pm 0.5^\circ\text{C}$	$\leq \pm 0.025^\circ\text{C} / ^\circ\text{C}$
TC type: B <sup>1</sup> , Lr, R, S, W3, W5	$\leq \pm 1^\circ\text{C}$	$\leq \pm 0.1^\circ\text{C} / ^\circ\text{C}$
TC type: B <sup>2</sup>	$\leq \pm 3^\circ\text{C}$	$\leq \pm 0.3^\circ\text{C} / ^\circ\text{C}$
TC type: B <sup>3</sup>	$\leq \pm 8^\circ\text{C}$	$\leq \pm 0.8^\circ\text{C} / ^\circ\text{C}$
TC type: B <sup>4</sup>	not specified	not specified

TC B<sup>1</sup> accuracy specification range . . . . . > 400°C  
 TC B<sup>2</sup> accuracy specification range . . . . . > 160°C < 400°C  
 TC B<sup>3</sup> accuracy specification range . . . . . > 85°C < 160°C  
 TC B<sup>4</sup> accuracy specification range . . . . . < 85°C

TC cold junction compensation. . . . . < ±1.0°C  
 Max. offset on input signal . . . . . 50% of selec. max. value

EMC - immunity influence. . . . .	< ±0.1% of span
Extended EMC immunity: NAMUR NE 21, A criterion, burst . . . . .	< ±1% of span

**Input specifications:**

**RTD input types:**

RTD type	Min. value	Max. value	Min. span	Standard
Pt100	-200°C	+850°C	10°C	IEC 60751
Ni100	-60°C	+250°C	10°C	DIN 43760
Lin. R	0 Ω	7000 Ω	25 Ω	----

Pt50, Pt100, Pt200, Pt500, Pt1000, Ni50, Ni100, Ni120, Ni1000  
 Cable resistance per wire (max.). . . . . 5 Ω  
 (up to 50 Ω per wire is possible with reduced measurement accuracy)  
 Sensor current . . . . . Nom. 0.2 mA

**TC input types:**

Type	Min. temperature	Max. temperature	Min. span	Standard
B	0°C	+1820°C	100°C	IEC584
E	-100°C	+1000°C	50°C	IEC584
J	-100°C	+1200°C	50°C	IEC584
K	-180°C	+1372°C	50°C	IEC584
L	-200°C	+900°C	50°C	DIN 43710
Lr	-200°C	+800°C	50°C	GOST 3044-84
N	-180°C	+1300°C	50°C	IEC584
R	-50°C	+1760°C	100°C	IEC584
S	-50°C	+1760°C	100°C	IEC584
T	-200°C	+400°C	50°C	IEC584
U	-200°C	+600°C	50°C	DIN 43710
W3	0°C	+2300°C	100°C	ASTM E988-90
W5	0°C	+2300°C	100°C	ASTM E988-90

Cold junction compensation (CJC):

Constant, internal or external via a Pt100 or Ni100 sensor

**mV input:**

Measurement range . . . . . -800...+800 mV  
 Min. span . . . . . 2.5 mV  
 Input resistance . . . . . 10 MΩ

**Output specifications and HART:**

Signal range. . . . . 4...20 mA  
 Min. signal range. . . . . 16 mA  
 Updating time . . . . . 440 ms  
 Load resistance. . . . .  $\leq (V_{\text{supply}} - 8) / 0.023 [\Omega]$   
 Sensor error detection, programmable . . . . . 3.5...23 mA  
 (shorted sensor error detection is ignored at TC and mV input)  
 NAMUR NE43 Upscale . . . . . 23 mA  
 NAMUR NE43 Downscale. . . . . 3.5 mA  
 HART protocol revisions. . . . . HART 5 and HART 7

of span = of the presently selected range

**Observed authority requirements:**

EMC. . . . . 2014/30/EU  
 RoHS. . . . . 2011/65/EU  
 ATEX . . . . . 2014/34/EU  
 EAC . . . . . TR-CU 020/2011  
 EAC Ex . . . . . TR-CU 012/2011

**Approvals:**

DNV-GL, Ships &amp; Offshore . . . . . TAA0000101

**I.S. / Ex approvals:**

5337A:  
 ATEX . . . . . KEMA 03ATEX1508 X  
 5337D:  
 ATEX . . . . . KEMA 030ATEX1537  
 FM . . . . . FM17US0013X  
 5337A & 5337D:  
 IECEx. . . . . IECEx KEM 10.0083X  
 CSA . . . . . 1125003  
 INMETRO . . . . . DEKRA 18.0002X  
 EAC Ex . . . . . RU C-DK.HA65.B.00355/19

**Functional Safety:**

Hardware assessed for use in SIL applications  
 FMEDA report - [www.prelectronics.com](http://www.prelectronics.com)

## Changing the HART protocol version

It is possible to change the unit's HART protocol revision by using the PReset software and a PR 5909 Loop Link interface or a HART interface.

Other HART configuration tools like a Handheld HART Terminal may also be used.

**Procedure for using a HART hand-held terminal to change the 5337 from HART 7 to HART 5 and vice versa:**

### Change the 5337 from HART 7 to HART 5:

Drive the 5337 device **Online** and enter **Device setup - Diag/Service**.

Select **Write protection** and **Write protect** by entering "\*\*\*\*\*" (8 stars).

Select **New password** - type "\*\*\*\*\*" (8 stars) & then "HARTREV5".

Select **Write enable** by entering "-CHANGE-".

### Change the 5335 (5337) from HART 5 to HART 7:

Drive the 5335 device **Online** and enter **Device setup - Diag/Service**.

Select **Write protection** and **Write protect** by entering "\*\*\*\*\*" (8 stars).

Select **New password** - type "\*\*\*\*\*" (8 stars) & then "HARTREV7".

Select **Write enable** and enter "-CHANGE-".

**Please note this is only possible if the transmitter is marked "5337" on the label!**

**Changing the HART protocol version using the PReset software and 5909 Loop Link or HART communication interface**

### Switching from HART 7 to HART 5:

Select the 5337 product, click the "HART" tab and open the folder "Methods".

Click **Device Password / Write Protection / Protocol...** and select "Change protocol to HART 5" in the pop-up window, then acknowledge by pressing OK.

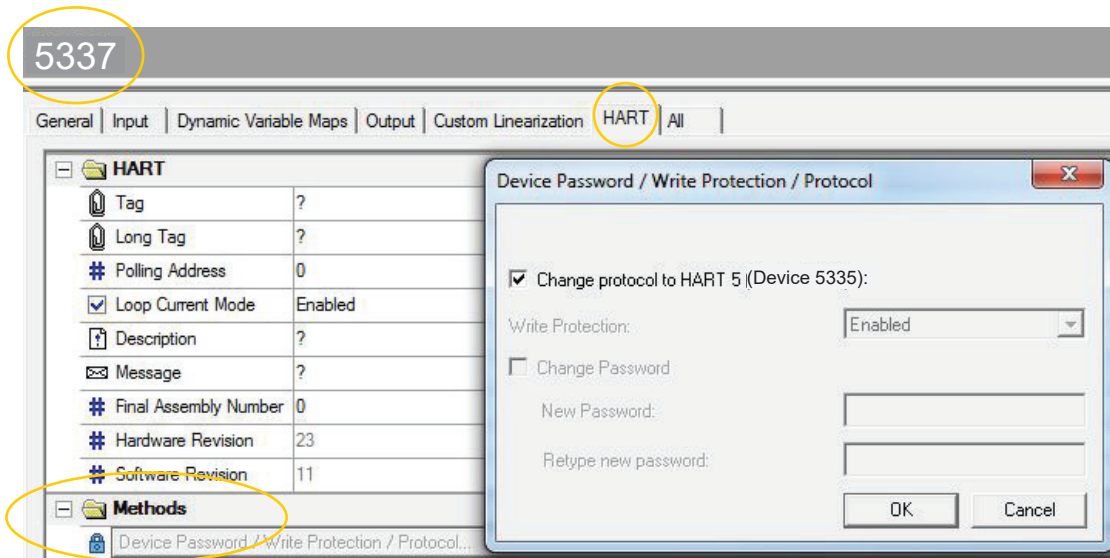



The following message will now appear:

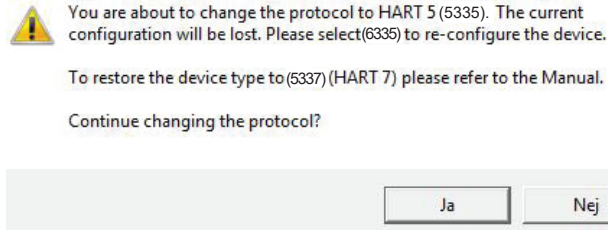

If you press "Ja" (Yes):

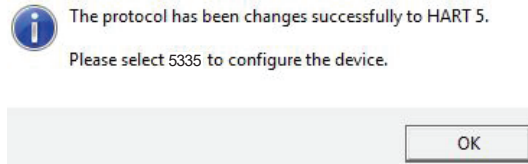

### Switching from HART 5 to HART 7:

Please note this is only possible if the transmitter is marked "5337" on the label!

From PReset, select the 5335 product, click the "OPTIONS" tab click "Protect". Write protection must be set to "ON". Select **Change Password**. Type in the new password "HARTREV7" and Re-enter "HARTREV7". Click OK.

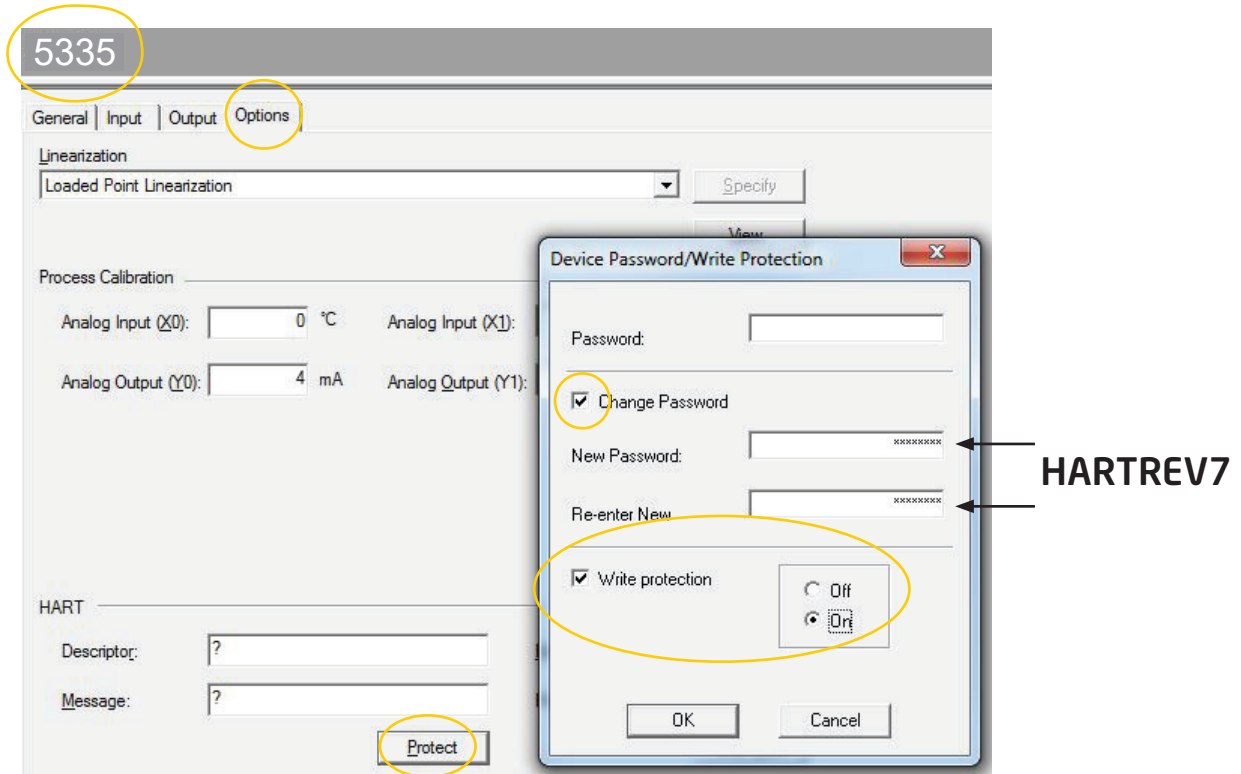

Switch **Write protection OFF** and write-enable the device by typing in the **Password "-CHANGE-"** in the top menu - acknowledge by pressing OK.

This action will reset the password to the default active password "\*\*\*\*\*" (8 stars) and restart the device in the updated HART 7 mode with write protection disabled. Now, select 5337 in PReset and reconfigure the device.

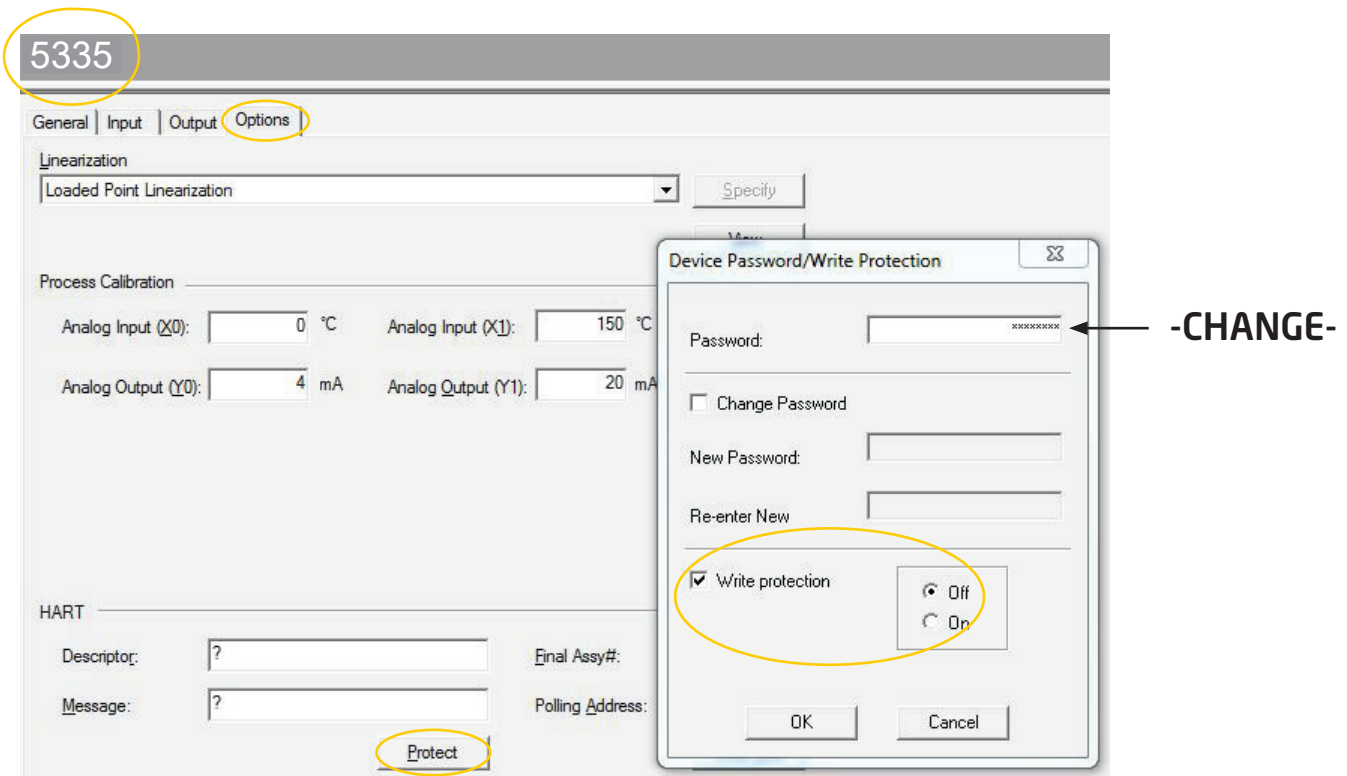

# Connections

## Input:

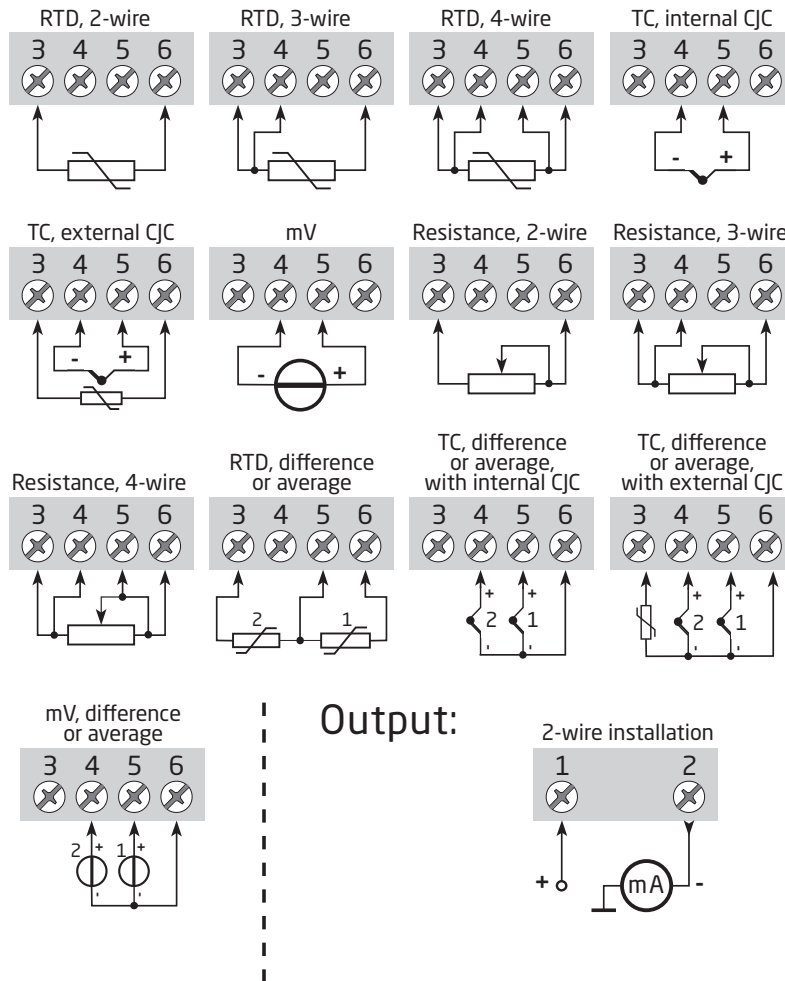

## Block diagram

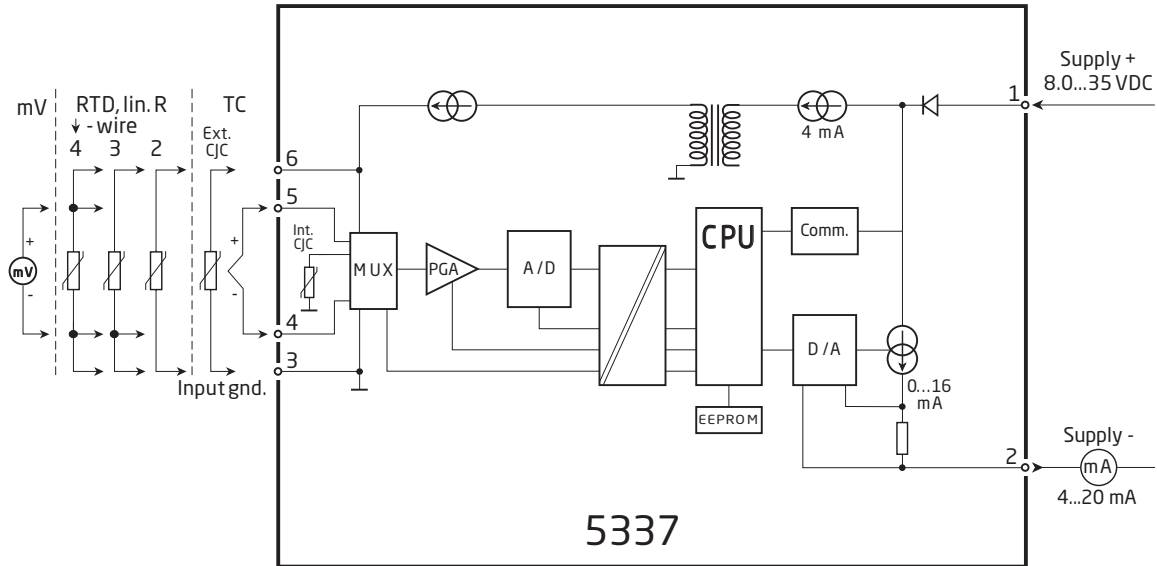

## Programming

5337 can be configured in the following 3 ways:

1. With PR electronics A/S' communications interface Loop Link and PReset PC configuration software.
2. With a HART modem and PReset PC configuration software.
3. With a HART communicator with PR electronics A/S' DDL driver.

### 1: Loop Link

For programming please refer to the drawing below and the help functions in PReset.

Loop Link is not approved for communication with devices installed in hazardous (Ex) area.

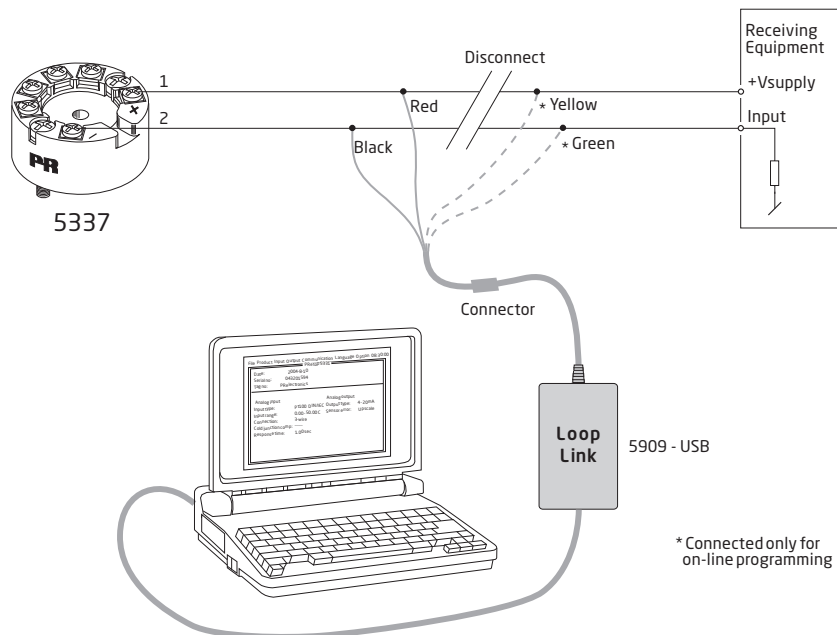

## 2: HART modem

For programming please refer to the drawing below and the help functions in PRreset.

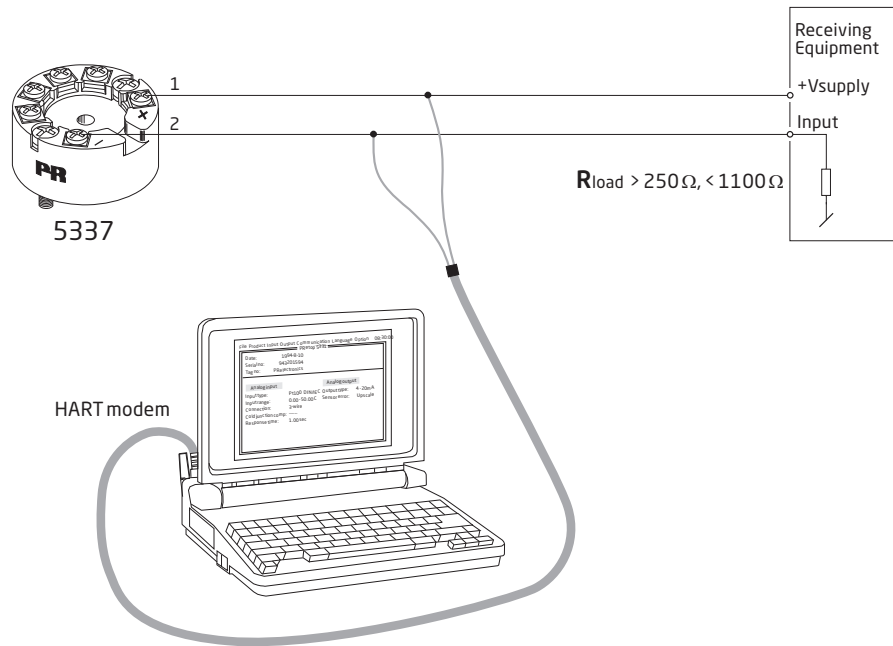

## 3: HART communicator

For programming please refer to the drawing below. To get access to productspecific commands, the HART communicator must be loaded with the PR electronics A/S DDL driver. This can be ordered either at the HART Communication Foundation or PR electronics A/S.

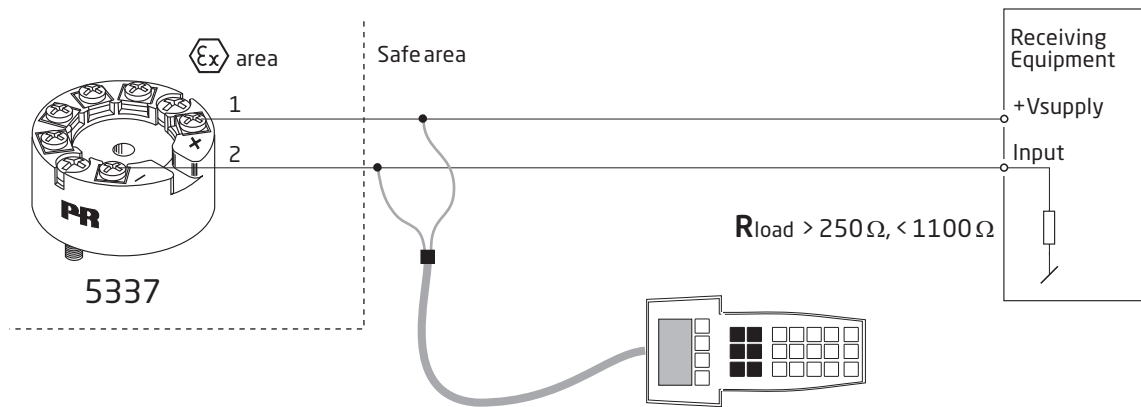

## Connection of transmitters in multidrop mode

- The HART communicator or a PC modem can be connected across AB or BC.

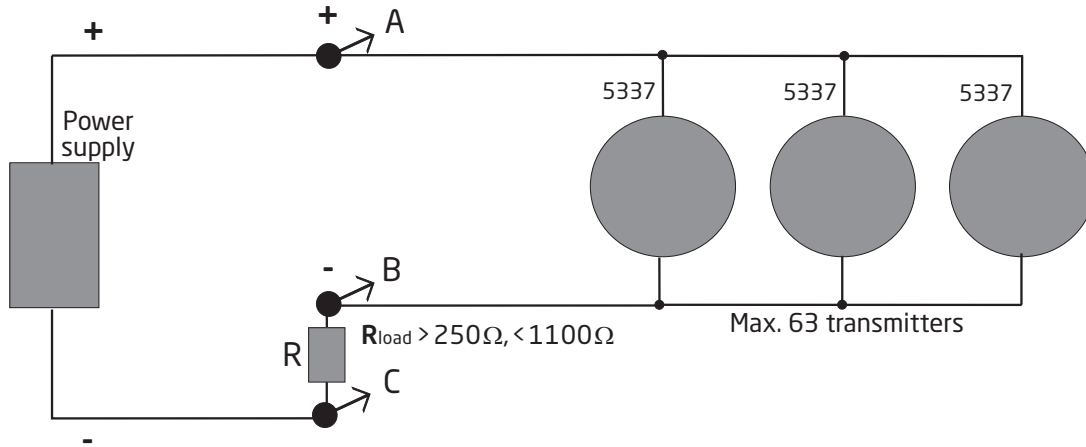

- The outputs of max. 63 transmitters can be connected in parallel for a digital HART communication on 2-wires.
- Before it is connected, each transmitter must be configured with a unique number from 1 to 63. If 2 transmitters are configured with the same number, both will be excluded. The transmitters must be programmed for multidrop mode (with a fixed output signal of 4 mA). Maximum current in the loop is therefore 252 mA.
- The communication is either by means of a HART communicator or a HART modem.
- The PReset PC configuration software can configure the individual transmitter for multidrop mode and provide it with a unique polling address.

### Mechanical specifications

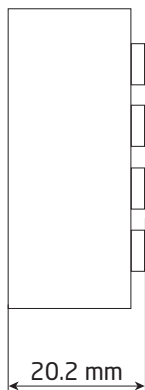
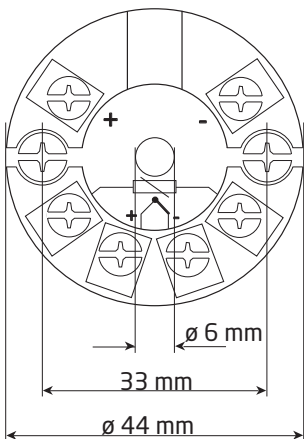

### Mounting of sensor wires

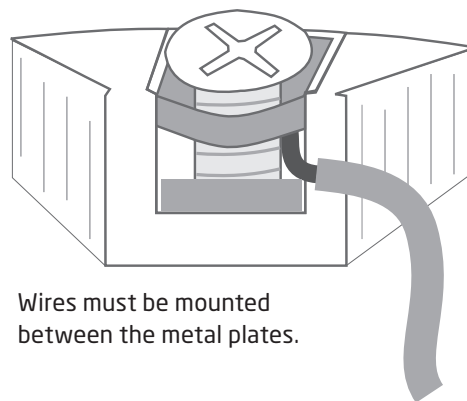

## ATEX Installation drawing 5335QA02



For safe installation of 5335A, or 5337A the following must be observed. The module shall only be installed by qualified personnel who are familiar with the national and international laws, directives and standards that apply to this area.  
Year of manufacture can be taken from the first two digits in the serial number.

ATEX Certificate      KEMA 03ATEX 1508X

Marking



II 3 G Ex nA [ic] IIC T6..T4 Gc  
II 3 G Ex ic IIC T6..T4 Gc  
II 3 D Ex ic IIIC Dc

Standards

EN 60079-0:2012, EN 60079-11:2012, EN 60079-15:2010

T4:  $-40 \leq T_a \leq 85^\circ\text{C}$   
T6:  $-40 \leq T_a \leq 60^\circ\text{C}$

**Terminal: 3,4,5,6**  
Ex nA [ic]

**Terminal: 1,2**  
Ex nA

**Terminal: 1,2**  
Ex ic

Uo: 9.6 V  
Io: 28 mA  
Po: 67 mW  
Lo: 45 mH  
Co: 28  $\mu\text{F}$

$U \leq 35 \text{ VDC}$   
 $I = 4 - 20 \text{ mA}$

$U_i = 35 \text{ VDC}$   
 $L_i = 10 \mu\text{H}$   
 $C_i = 1.0 \text{ nF}$

### General installation instructions

If the enclosure is made of non-metallic materials or of painted metal, electrostatic charging shall be avoided.

For an ambient temperature  $\geq 60^\circ\text{C}$ , heat resistant cables shall be used with a rating of at least 20 K above the ambient temperature.

For installation in a potentially explosive gas atmosphere, the following instructions apply:

For "Ex ic" the transmitter must be installed in an enclosure providing a degree of protection of at least IP20 according to EN60529 that is suitable for the application and is correctly installed.

For "Ex nA" the transmitter must be installed in an enclosure providing a degree of protection of at least IP54 according to EN60529 that is suitable for the application and is correctly installed, or in an enclosure with type of protection Ex n or Ex e.

Cable entry devices and blanking elements shall fulfill the same requirements.

For installation in a potentially explosive dust atmosphere, the following instructions apply:

If the transmitter is supplied with an intrinsically safe signal "ic" and interfaces an intrinsically safe signal "ic" (e.g. a passive device), the transmitter shall be mounted in a metal enclosure form B according to DIN 43729 that provides a degree of protection of at least IP6X according to EN60529, and that is suitable for the application. Cable entry devices and blanking elements shall fulfill the same requirements.

If the transmitter is supplied with an non-sparking signal "nA", or interfaces a non sparking signal, the transmitter shall be mounted in a metal enclosure form B according to DIN 43729 providing a degree of protection of at least IP6X according to EN60529, and in conformance with type of protection Ex tD and suitable for the application. Cable entry devices and blanking elements shall fulfill the same requirements.



## ATEX Installation drawing 5335QA01



For safe installation of 5335D or 5337D the following must be observed. The module shall only be installed by qualified personnel who are familiar with the national and international laws, directives and standards that apply to this area.  
Year of manufacture can be taken from the first two digits in the serial number.

ATEX Certificate      KEMA 03ATEX 1537

Marking



II 1 G Ex ia IIC T6 ...T4 Ga  
II 1 D Ex ia IIIC Da  
I M1 Ex ia I Ma

Standards:            EN 60079-0 : 2012, EN 60079-11 : 2012, EN 60079-26 : 2007

Hazardous area

Zone 0, 1, 2, 20, 21, 22, and Coal mining

T4:  $-40 \leq T_a \leq 85^\circ\text{C}$

T6:  $-40 \leq T_a \leq 60^\circ\text{C}$

**Terminal: 3,4,5,6**

Uo: 9.6 VDC

Io: 28 mA

Po: 67 mW

Lo: 35 mH

Co: 3.5  $\mu\text{F}$

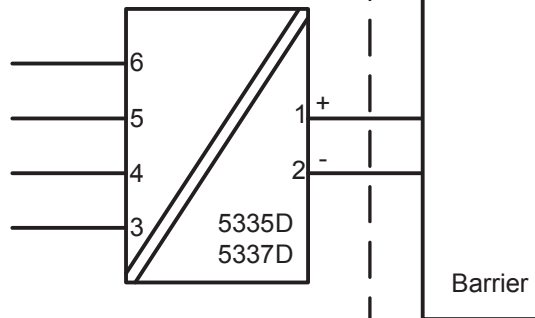

**Terminal: 1,2**

Ui: 30 VDC

Ii: 120 mA

Pi: 0.84 W

Li: 10  $\mu\text{H}$

Ci: 1.0 nF

**Installation notes.**

## General installation instructions

The sensor circuit is not infallibly galvanic isolated from the supply output circuit. However, the galvanic isolation between the circuits is capable of withstanding a test voltage of 500Vac during 1 minute.

If the enclosure is made of aluminium, it must be installed such, that even in the event of rare incidents, ignition sources due to impact and friction, sparks are excluded.

If the enclosure is made of non-metallic materials or painted metals electrostatic charging shall be avoided.

For installation in a potentially explosive gas atmosphere, the following instructions apply:

The transmitter shall be mounted in an enclosure form B according to DIN43729 or equivalent that is providing a degree of protection of at least IP20 according to EN60529 that is suitable for the application and correctly installed.

For installation in a potentially explosive dust atmosphere, the following instructions apply:

The transmitter shall be mounted in a metal enclosure form B according to DIN43729 or equivalent, that is providing a degree of protection of at least IP6X according to EN60529 that is suitable for the application and correctly installed.

Cable entries and blanking elements shall be used that are suitable for the application and correctly installed.

For installation in mines the following instructions apply:

The transmitter shall be mounted in a metal enclosure that is providing a degree of protection of at least IP6X according to EN60529, and is suitable for the application and correctly installed.

Cable entries and blanking elements shall be used that are suitable for the application and correctly installed

If the enclosure is made of aluminum, it must be installed such, that even in the event of rare incidents, ignition sources due to impact and friction, sparks are excluded.

If the enclosure is made of non-metallic materials or painted metals electrostatic charging shall be avoided.

The enclosure shall not contain by mass more than

a) 15 % in total of aluminium, magnesium, titanium and zirconium, and

b) 7,5 % in total of magnesium, titanium and zirconium.

## IECEx Installation drawing 5335QI02



For safe installation of 5335A or 5337A the following must be observed. The module shall only be installed by qualified personnel who are familiar with the national and international laws, directives and standards that apply to this area.  
Year of manufacture can be taken from the first two digits in the serial number.

IECEx Certificate IECEx KEM 10.0083X

Marking  
Ex nA [ic] IIC T6..T4 Gc  
Ex ic IIC T6..T4 Gc  
Ex ic IIIC Dc

Standards IEC 60079-0 : 2011, IEC 60079-11 : 2011, EN 60079-15 : 2010

T4: $-40 \leq T_a \leq 85^\circ\text{C}$	<b>Terminal: 3,4,5,6</b>	<b>Terminal: 1,2</b>	<b>Terminal: 1,2</b>
T6: $-40 \leq T_a \leq 60^\circ\text{C}$	Ex nA [ic]	Ex nA	Ex ic
	Uo: 9.6 V	U $\leq$ 35 VDC	Ui = 35 VDC
	Io: 28 mA	I = 4 - 20 mA	Li = 10 $\mu$ H
	Po: 67 mW		Ci = 1.0 nF
	Lo: 45 mH		
	Co: 28 $\mu$ F		

### General installation instructions

If the enclosure is made of non-metallic materials or of painted metal, electrostatic charging shall be avoided.

For an ambient temperature  $\geq 60^\circ\text{C}$ , heat resistant cables shall be used with a rating of at least 20 K above the ambient temperature.

For installation in a potentially explosive gas atmosphere, the following instructions apply:

For "Ex ic" the transmitter must be installed in an enclosure providing a degree of protection of at least IP20 according to IEC60529 that is suitable for the application and is correctly installed.

For "Ex nA" the transmitter must be installed in an enclosure providing a degree of protection of at least IP54 according to IEC60529 that is suitable for the application and is correctly installed, or in an enclosure with type of protection Ex n or Ex e.

Cable entry devices and blanking elements shall fulfill the same requirements

For installation in a potentially explosive dust atmosphere, the following instructions apply:

If the transmitter is supplied with an intrinsically safe signal "ic" and interfaces an intrinsically safe signal "ic" (e.g. a passive device), the transmitter shall be mounted in a metal enclosure form B according to DIN 43729 that provides a degree of protection of at least IP6X according to IEC60529, and that is suitable for the application. Cable entry devices and blanking elements shall fulfill the same requirements.

If the transmitter is supplied with a non-sparking signal "nA", or interfaces a non-sparking signal, the transmitter shall be mounted in a metal enclosure form B according to DIN 43729 providing a degree of protection of at least IP6X according to IEC60529, and in conformance with type of protection Ex tD and suitable for the application. Cable entry devices and blanking elements shall fulfill the same requirements.

## IECEX Installation drawing 5335QI01



For safe installation of 5335D or 5337D the following must be observed. The module shall only be installed by qualified personnel who are familiar with the national and international laws, directives and standards that apply to this area.

Year of manufacture can be taken from the first two digits in the serial number.

IECEX Certificate      IECEx KEM.10.0083X

Marking                Ex ia IIC T6..T4 Ga  
Ex ia IIIC Da  
Ex ia I Ma

Standards             IEC60079-11:2011, IEC60079-0: 2011, IEC60079-26:2006

Hazardous area  
Zone 0, 1, 2, 20, 21, 22 and Coal mining

T4:  $-40 \leq T_a \leq 85^\circ\text{C}$

T6:  $-40 \leq T_a \leq 45^\circ\text{C}$

Non Hazardous Area

**Terminal: 3,4,5,6**

Uo: 9.6 VDC

Io: 28 mA

Po: 67 mW

Lo: 35 mH

Co: 3.5  $\mu\text{F}$

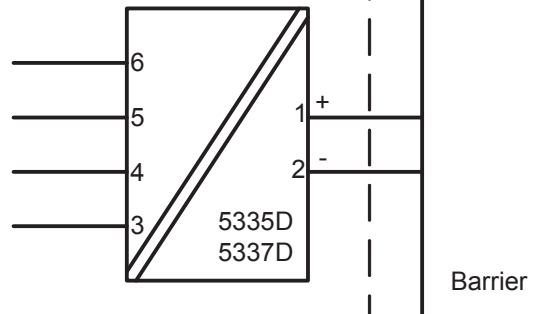

**Terminal: 1,2**

Ui: 30 VDC

Ii: 120 mA

Pi: 0.84 W

Li: 10  $\mu\text{H}$

Ci: 1.0 nF

**Installation notes.**

## General installation instructions

The sensor circuit is not infallibly galvanic isolated from the supply output circuit. However, the galvanic isolation between the circuits is capable of withstanding a test voltage of 500Vac during 1 minute.

If the enclosure is made of aluminium, it must be installed such, that even in the event of rare incidents, ignition sources due to impact and friction, sparks are excluded.

If the enclosure is made of non-metallic materials or painted metals electrostatic charging shall be avoided

For installation in a potentially explosive gas atmosphere, the following instructions apply:

The transmitter shall be mounted in an enclosure form B according to DIN43729 or equivalent that is providing a degree of protection of at least IP20 according to IEC 60529 that is suitable for the application and correctly installed.

For installation in a potentially explosive dust atmosphere, the following instructions apply:

The transmitter shall be mounted in a metal enclosure form B according to DIN43729 or equivalent, that is providing a degree of protection of at least IP6X according to IEC 60529 that is suitable for the application and correctly installed.

Cable entries and blanking elements shall be used that are suitable for the application and correctly installed.

For installation in mines the following instructions apply:

The transmitter shall be mounted in a metal enclosure that is providing a degree of protection of at least IP6X according to IEC 60529, and is suitable for the application and correctly installed.

Cable entries and blanking elements shall be used that are suitable for the application and correctly installed

If the enclosure is made of aluminium, it must be installed such, that even in the event of rare incidents, ignition sources due to impact and friction, sparks are excluded.

If the enclosure is made of non-metallic materials or painted metals electrostatic charging shall be avoided.

The enclosure shall not contain by mass more than

- a) 15 % in total of aluminium, magnesium, titanium and zirconium, and
- b) 7,5 % in total of magnesium, titanium and zirconium.

For safe installation of the 5335A and 5337A the following must be observed. The module shall only be installed by qualified personnel who are familiar with the national and international laws, directives and standards that apply to this area.

**Marking**

Class I, Division 2, Group A,B,C,D T4..T6  
 Class I Zone 2 Ex/AEx nA[ic] IIC T4..T6  
 Class I Zone 2 Ex/AEx nA IIC T4..T6  
 NIFW Class I Division 2, Group A,B,C,D

**Hazardous Area**  
 CL I, Div 2, GP ABCD  
 CL I, Zone 2, IIC

T4: -40°C to 85°C  
 T6: -40°C to 60°C

**Terminal:**

**3,4,5,6**  
 Uo: 9.6 VDC  
 Io: 28 mA  
 Po: 67 mW  
 Lo: 45 mH  
 Co: 28 µF

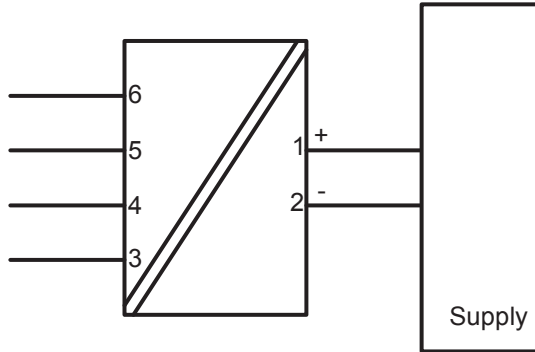

**Terminal:**

**1-2**  
 Functional Ratings:  
 U nominal ≤ 35 VDC;  
 I nominal ≤ 3.5 - 23 mA

**NI Installation instructions**

The transmitter must be installed in an enclosure providing a degree of protection of at least IP54 according to IEC60529 that is suitable for the application and is correctly installed. Cable entry devices and blanking elements shall fulfill the same requirements.

If the enclosure is made of non-metallic materials or of painted metal, electrostatic charging shall be avoided.

Use supply wires with a rating of at least 5 K above the ambient temperature.

Supply from a Class 2 Power Supply with Transient protection or equivalent.

WARNING: Substitution of components may impair suitability for Class I, Division 2

AVERTISSEMENT: la substitution de composants peut nuire à l'aptitude à la Classe I, Division 2.

WARNING: Do not disconnect equipment unless power has been switched off or the area is known to be safe.

AVERTISSEMENT: Ne débranchez pas l'équipement sauf si l'alimentation a été coupée ou si la zone est connue pour être sûre.

**Non Incendive field wiring installation**

The non incendive field Wiring Circuit concept allows interconnection of Nonincendive Field wiring Apparatus with Associated Nonincendive Field Wiring Apparatus or Associated Intrinsically Safe Apparatus or Associated Apparatus not specially examined in combination as a system using any of the wiring methods permitted for unclassified locations,

$Voc < Vmax$ ,  $Ca \geq Ci + Ccable$ ,  $La \geq Li + Lcable$ .

## CSA Installation drawing 533XQC03

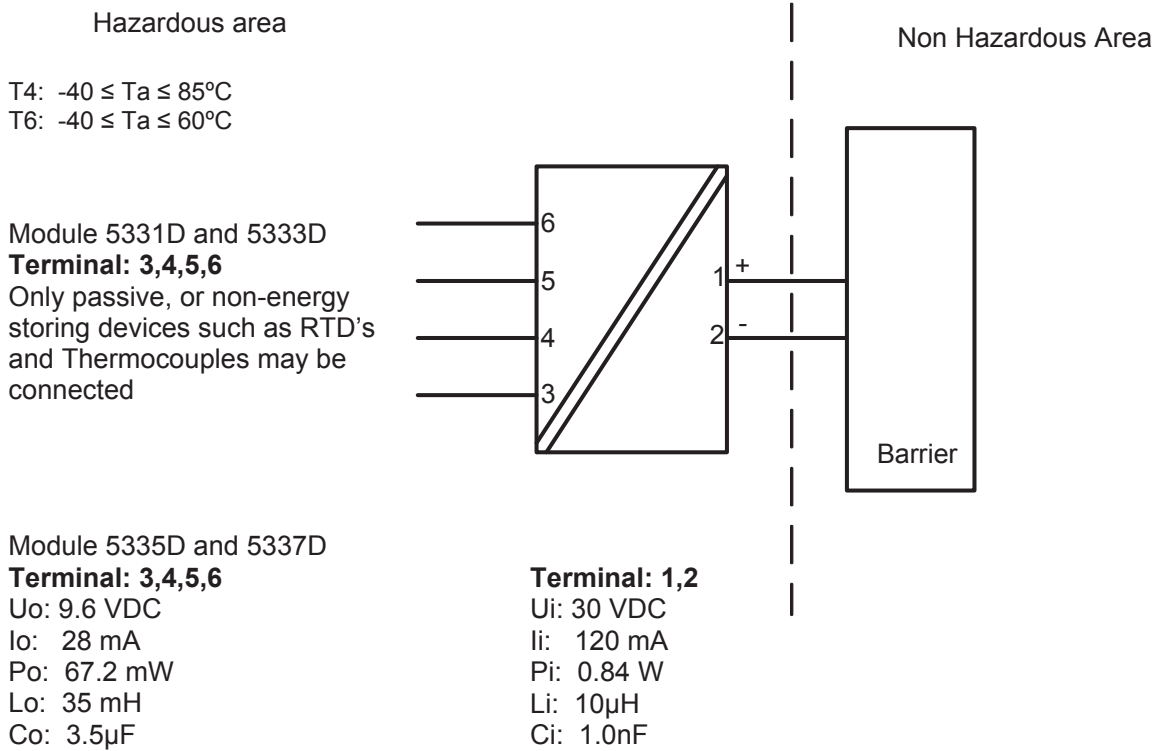

CLASS 2258 04 - PROCESS CONTROL EQUIPMENT - Intrinsically Safe Entity - For Hazardous Locations  
Class I, Division 1, Groups A, B, C and D  
Ex ia IIC, Ga

CLASS 2258 84 - PROCESS CONTROL EQUIPMENT - Intrinsically Safe Entity - For Hazardous Locations - Certified to US Standards  
Class I, Division 1, Groups A, B, C and D  
Class I, Zone 0, AEx ia IIC, Ga

**Warning:**

Substitution of components may impair intrinsic safety.

The transmitters must be installed in a suitable enclosure to meet installation codes stipulated in the Canadian Electrical Code (CEC) or for US the National Electrical Code (NEC).

## FM Installation Drawing

### Model 5331D, 5332D, 5333D and 5343B

#### Hazardous (Classified) Location

Class I, Division 1, Groups, A, B, C, D T4..T6  
Class I, Zone 0, AEx ia IIC T4..T6

Ambient temperature limits  
T4: -40 to + 85 deg. Celcius  
T6: -40 to + 60 deg. Celcius

Terminal 1 , 2  
Vmax or Ui: 30 V  
Imax or li: 120 mA  
Pmax or Pi: 0.84 W  
Ci: 1 nF  
Li: 10 uH

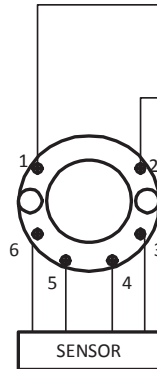

#### Non Hazardous Location

Associated Apparatus  
or Barrier  
with  
entity Parameters:

$UM \leq 250V$   
 $Voc \text{ or } Uo \leq Vmax \text{ or } Ui$   
 $Isc \text{ or } Io \leq Imax \text{ or } li$   
 $Po \leq Pi$   
 $Ca \text{ or } Co \geq Ci + Ccable$   
 $La \text{ or } Lo \geq Li + Lcable$

This device must not be connected  
to any associated apparatus which  
uses or generates more than 250  
VRMS

### Model 5335D, 5337D

#### Hazardous (Classified) Location

Class I, Division 1, Groups, A, B, C, D T4..T6  
Class I, Zone 0, AEx ia IIC T4..T6

Ambient temperature limits  
T4: -40 to + 85 deg. Celcius  
T6: -40 to + 60 deg. Celcius

Terminal 1 , 2  
Vmax or Ui: 30 V  
Imax or li: 120 mA  
Pmax or Pi: 0.84 W  
Ci: 1 nF  
Li: 10 uH

Terminal 3,4,5,6  
Vt or Uo: 9.6 V  
It or Io: 28 mA  
Pt or Po: 67.2 mW  
Ca or Co: 3.5 uF  
La or Lo: 35 mH

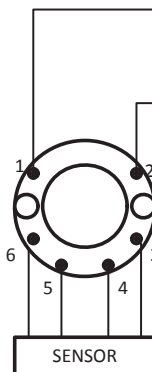

#### Non Hazardous Location

Associated Apparatus  
or Barrier  
with  
entity Parameters:

$UM \leq 250V$   
 $Voc \text{ or } Uo \leq Vmax \text{ or } Ui$   
 $Isc \text{ or } Io \leq Imax \text{ or } li$   
 $Po \leq Pi$   
 $Ca \text{ or } Co \geq Ci + Ccable$   
 $La \text{ or } Lo \geq Li + Lcable$

This device must not be connected  
to any associated apparatus which  
uses or generates more than 250  
VRMS



**The entity concept**

The Transmitter must be installed according to National Electrical Code (ANSI-NFPA 70) and shall be installed with the enclosure, mounting, and spacing segregation requirement of the ultimate application.

Equipment that is FM-approved for intrinsic safety may be connected to barriers based on the ENTITY CONCEPT. This concept permits interconnection of approved transmitters, meters and other devices in combinations which have not been specifically examined by FM, provided that the agency's criteria are met. The combination is then intrinsically safe, if the entity concept is acceptable to the authority having jurisdiction over the installation.

The entity concept criteria are as follows:

The intrinsically safe devices, other than barriers, must not be a source of power.

The maximum voltage  $U_i(V_{MAX})$  and current  $I_i(I_{MAX})$ , and maximum power  $P_i(P_{max})$ , which the device can receive and remain intrinsically safe, must be equal to or greater than the voltage ( $U_o$  or  $V_{OC}$  or  $V_t$ ) and current ( $I_o$  or  $I_{SC}$  or  $I_t$ ) and the power  $P_o$  which can be delivered by the barrier.

The sum of the maximum unprotected capacitance ( $C_i$ ) for each intrinsically device and the interconnecting wiring must be less than the capacitance ( $C_a$ ) which can be safely connected to the barrier.

The sum of the maximum unprotected inductance ( $L_i$ ) for each intrinsically device and the interconnecting wiring must be less than the inductance ( $L_a$ ) which can be safely connected to the barrier.

The entity parameters  $U_o, V_{OC}$  or  $V_t$  and  $I_o, I_{SC}$  or  $I_t$ , and  $C_a$  and  $L_a$  for barriers are provided by the barrier manufacturer.

**NI Field Circuit Parameters**

**Model 5331D, 5332D, 5333D, 5335D, 5337D and 5343B**

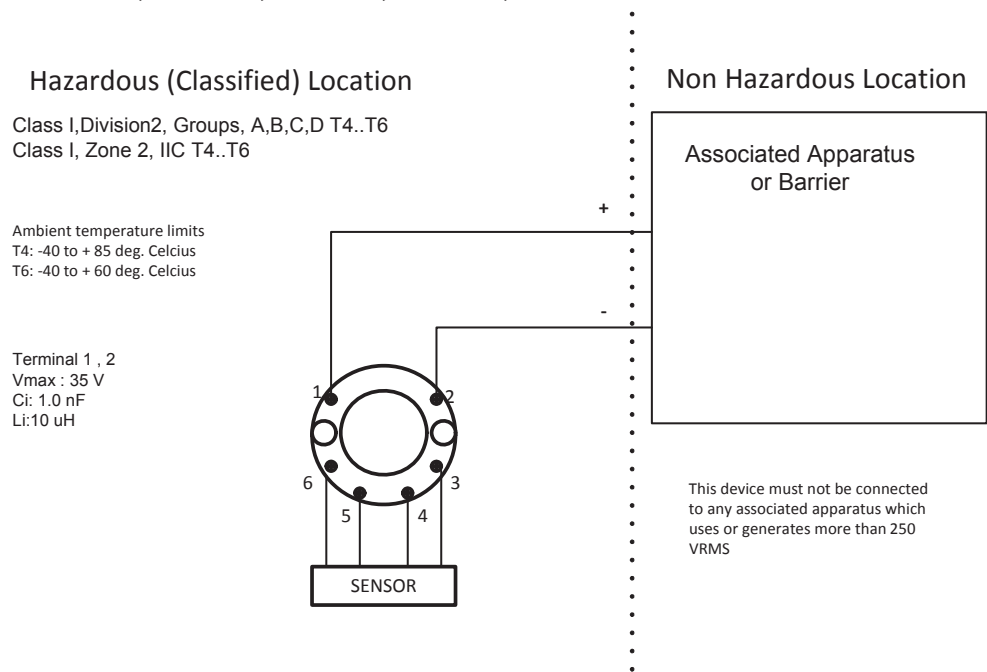

## Instalação INMETRO 5335QB01-V8R0



Para uma instalação segura, o seguinte deve ser observado. O módulo só deve ser instalado por pessoal qualificado e familiarizado com as leis, diretrizes e normas nacionais e internacionais aplicáveis a essa área.

Certificado DEKRA18.0002X

Normas ABNT NBR IEC 60079-0:2013 Versão corrigida 2: 2016  
ABNT NBR IEC 60079-11:2013 : Versão corrigida 2017  
ABNT NBR IEC 60079-15:2012

5335D, 5337D:

Notas Ex ia IIC T6...T4 Ga  
Ex ia IIIC Da  
Ex ia I Ma

### Área Classificada

Zona 0, 1, 2, 20, 21, 22 e mineração de carvão

T4:  $-40 \leq T_a \leq 85^\circ\text{C}$

T6:  $-40 \leq T_a \leq 45^\circ\text{C}$

### Terminais :

**3,4,5,6**

Uo: 9.6 VDC

Io: 28 mA

Po: 67 mW

Lo: 35 mH

Co: 3.5µF

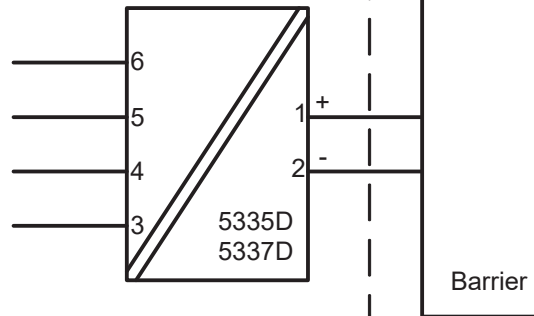

### Terminais: 1,2

Ui: 30 VDC

Ii: 120 mA

Pi: 0.84 W

Li: 10µH

Ci: 1.0nF

**Instruções Gerais de Instalação.**

O circuito do sensor não é galvanicamente infalivelmente isolado do circuito de saída de alimentação. No entanto, o isolamento galvânico entre os circuitos é capaz de suportar uma tensão de teste de 500Vac durante 1 minuto.

Se o invólucro for feito de alumínio, ele deve ser instalado de tal forma que, mesmo em caso de incidentes raros, fontes de ignição devidas a impactos e fricção, faíscas sejam excluídas. Se o invólucro for feito de materiais não metálicos ou metais pintados, o carregamento eletrostático deve ser evitado.

Para instalações com uma atmosfera de gás potencialmente explosiva, a seguinte instrução se aplicará:

O transmissor deverá ser montado em um gabinete de formato tipo B de acordo com a norma DIN43729 ou equivalente que possibilite um grau mínimo de proteção IP20 de acordo com a ABNT NBR IEC60529 adequado para a aplicação e instalado corretamente.

Para instalação em uma atmosfera de poeira potencialmente explosiva, as seguintes instruções se aplicam:

O transmissor deve ser montado em um invólucro metálico B de acordo com DIN43729 ou equivalente que esteja fornecendo um grau de proteção de pelo menos IP6X de acordo com a ABNT NBR IEC 60529 que seja adequado para a aplicação e instalado corretamente..

Entradas de cabos e bujões de fechamento' devem ser usados adequados à aplicação e instalados corretamente.

Para instalação em minas, as seguintes instruções se aplicam:

O transmissor deve ser montado em um invólucro de metal que forneça um grau de proteção de pelo menos IP6X de acordo com a ABNT NBR IEC 60529 e seja adequado para a aplicação e instalado corretamente.

Entradas de cabos e bujões de fechamento' devem ser usados adequados à aplicação e instalados corretamente.

Se o invólucro for feito de alumínio, ele deve ser instalado de tal forma que, mesmo em caso de incidentes raros, fontes de ignição devidas a impactos e fricção, faíscas sejam excluídas.

Se o invólucro for feito de materiais não metálicos ou metais pintados, o carregamento eletrostático deve ser evitado.

O recinto não deve conter mais de massa

a) 15% no total de alumínio, magnésio, titânio e zircônio e

b) 7,5% no total de magnésio, titânio e zircônio.

5335A, 5337A:

Notas Ex nA [ic] IIC T6..T4 Gc  
Ex ic IIC T6..T4 Gc  
Ex ic IIIC Dc

T4: $-40 \leq T_a \leq 85^\circ\text{C}$	<b>Terminais: 3,4,5,6</b>	<b>Terminais: 1,2</b>	<b>Terminais: 1,2</b>
T6: $-40 \leq T_a \leq 60^\circ\text{C}$	Ex nA [ic]	Ex nA	Ex ic
	Uo: 9.6 V	U $\leq$ 35 VDC	Ui = 35 VDC
	Io: 28 mA	I = 4 - 20 mA	Li = 10 $\mu\text{H}$
	Po: 67 mW		Ci = 1.0 nF
	Lo: 45 mH		
	Co: 28 $\mu\text{F}$		

**Instruções gerais de instalação**

Se o invólucro for feito de materiais não metálicos ou de metal pintado, o carregamento eletrostático deve ser evitado.  
Para uma temperatura ambiente  $\geq 60^\circ\text{C}$ , devem ser utilizados cabos resistentes ao calor com uma classificação de pelo menos 20 K acima da temperatura ambiente.

Para instalação em uma atmosfera de gás potencialmente explosiva, as seguintes instruções se aplicam:

Para "Ex ic", o transmissor deve ser instalado em um gabinete que ofereça um grau de proteção de pelo menos IP20 de acordo com a ABNT NBR IEC60529, adequado para a aplicação e que esteja instalado corretamente.  
Para "Ex nA" o transmissor deve ser instalado em um invólucro que ofereça um grau de proteção de pelo menos IP54 de acordo com a ABNT NBR IEC60529 que seja adequado para a aplicação e esteja corretamente instalado, ou em um invólucro com tipo de proteção Ex n ou Ex e. Dispositivos de entrada de cabos e bujões de fechamento' devem cumprir os mesmos requisitos

Para instalação em atmosferas potencialmente explosivas, aplicam-se as seguintes instruções:

Se o transmissor for fornecido com um sinal intrinsecamente seguro "ic" e fizer a interface de um sinal intrinsecamente seguro "ic" (por exemplo, um dispositivo passivo), o transmissor será montado em um invólucro metálico B de acordo com a norma DIN 43729 que fornece um grau de proteção pelo menos IP6X de acordo com a ABNT NBR IEC60529, e é adequado para a aplicação. Dispositivos de entrada de cabos e bujões de fechamento' devem atender aos mesmos requisitos.

Se o transmissor for fornecido com um sinal não centelhante "nA" ou fizer a interface de um sinal não centelhante, o transmissor será montado em um invólucro metálico B de acordo com a norma DIN 43729, proporcionando um grau de proteção de pelo menos IP6X conforme ABNT NBR. IEC60529, e em conformidade com o tipo de proteção Ex t e adequado para a aplicação. Dispositivos de entrada de cabos e bujões de fechamento' devem atender aos mesmos requisitos.

## Document history

The following list provides notes concerning revisions of this document.

<b>Rev. ID</b>	<b>Date</b>	<b>Notes</b>
104	1837	Specifications for internal power dissipation added. INMETRO certification changed to DEKRA. FM certificate number updated.
105	2006	FM installation drawing updated. CSA approval for 5337A received. Installation drawing added.

# We are near you, *all over the world*

**Our trusted red boxes are supported wherever you are**

All our devices are backed by expert service and a 5-year warranty. With each product you purchase, you receive personal technical support and guidance, day-to-day delivery, repair without charge within the warranty period and easily accessible documentation.

We are headquartered in Denmark, and have offices and authorized partners the world over. We are a local business

with a global reach. This means that we are always nearby and know your local markets well.

We are committed to your satisfaction and provide PERFORMANCE MADE SMARTER all around the world.

For more information on our warranty program, or to meet with a sales representative in your region, visit [prelectronics.com](http://prelectronics.com).

# Benefit today from *PERFORMANCE MADE SMARTER*

PR electronics is the leading technology company specialized in making industrial process control safer, more reliable and more efficient. Since 1974, we have been dedicated to perfecting our core competence of innovating high precision technology with low power consumption. This dedication continues to set new standards for products communicating, monitoring and connecting our customers' process measurement points to their process control systems.

Our innovative, patented technologies are derived from our extensive R&D facilities and from having a great understanding of our customers' needs and processes. We are guided by principles of simplicity, focus, courage and excellence, enabling some of the world's greatest companies to achieve PERFORMANCE MADE SMARTER.